

1. POWER

+ Power (11-15 VDC): connection terminal for AF M5.11 bit power supply positive pole. The jack accepts a stripped cable up to 15mm/0.6" with maximum section of 4 AWG (\varnothing 5,1mm / 0.2"). For better power transfer we recommend using cables with the largest possible cross-section and with the same cross-section as the cable connected to the negative pole and the use of the Ferrules provided in the box.

- Power (Ground): connection terminal for the negative power supply pole of the amplifier. Connect here the negative battery cable or a cable connected to the vehicle chassis. The socket will take a stripped cable up to 15mm/0.6" with a maximum section of 4 AWG (\varnothing 5,1mm / 0.2"). For better power transfer, we recommend using cables with the largest possible section and with the same section as the cable connected to the positive pole the use of the Ferrules provided in the box. In order to correctly connect the ground (-), use a screw that is already present on the metal part of the vehicle; If necessary, remove any paint residue or grease, using a tester to make sure there is continuity between the negative terminal (-) on the battery and the mounting point. If possible, connect all of the grounds

on the audio components to the same grounding point. This helps reduce most of the interference than can occur in audio reproduction.

WARNING: make sure the connection polarity is as indicated on the terminals. A misconnection may result in damage to the AF M5.11 bit. After applying power, wait at least 10 seconds before turning the AF M5.11 bit on.

Multiple power supply connection

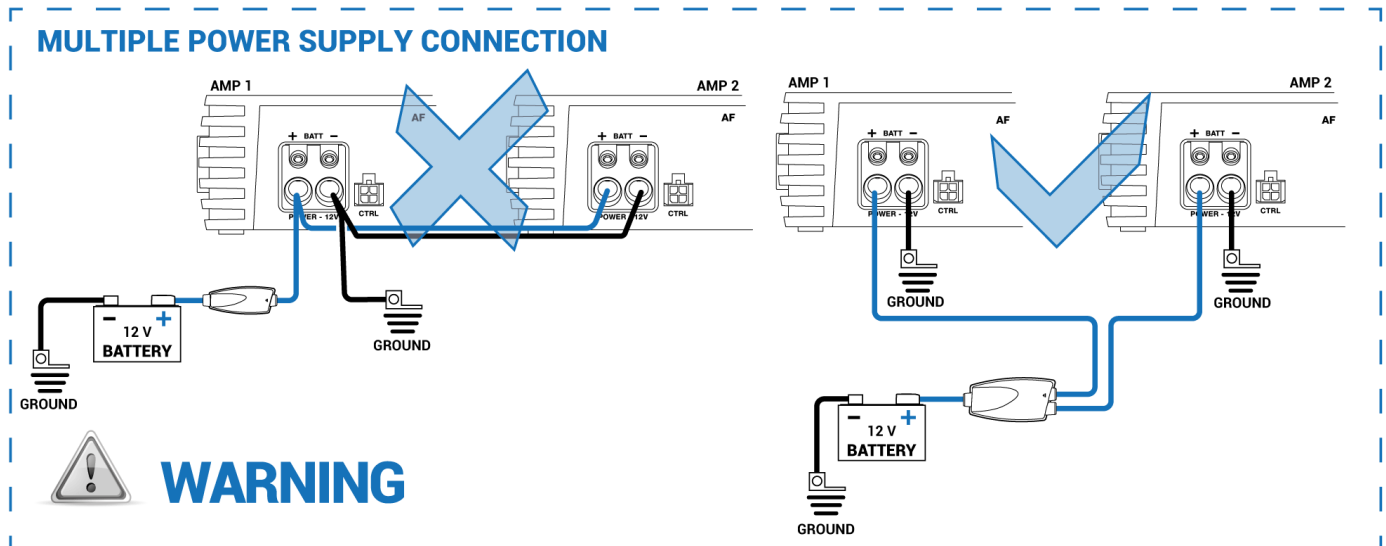

How to turn on the AF M5.11 bit

The AF C8.14 bit is turned ON when the FORZA logo is blue. It can be turned ON/OFF using the following methods:

1. **By REMOTE IN:** by connecting the REMOTE IN terminal with a Remote Out signal coming from an after market audio source, that will enable the amplifier turn on and off function.
2. **By SPEAKER IN:** by connecting the high level output signal of an OEM source to the IN1 - IN2 terminals of the SPEAKER IN connector and setting the ART switch to ON. In this way the AUTO TURN ON (ART) function is activated to turn on the amplifier when high level signal is present. By setting the ART selector to OFF, this function is disabled.
3. **By DRC AC:** by lightly pressing the DRC AC knob (turn ON). With a long press on the DRC AC knob (turn OFF). In this case, no other connections are required for turn on the device.

Note: if the amplifier has been turned on by REM IN wire, it can be turned off only by the same REM IN. Instead, if the amplifier has been turned on by DRC AC, then it can be turned off by either DRC AC or REM IN signal.

2. CTRL (REM IN-OUT / CONTROLS)

terminals to turn on and control the AF M5.11 bit:

- **Remote IN:** input to turn on AF M5.11 bit remotely through the audio signal source Remote Out. REM IN can be connected to the ignition switch terminal (ACC). The voltage must be between 7 and 14.5 VDC. If using a source with amplified outputs such as BTL, AF M5.11 bit can be automatically turned on ([see sec. 4.10](#)), so it will not be necessary to connect the REM IN terminal.
- **Remote OUT:** output to turn on other devices/amplifiers connected after the AF M5.11 bit. From the time it is turned on, it takes 12 seconds to supply the signal to the REM OUT output, but it will be possible to set this delay via software ([see sec. 4.17 FEATURES](#)). The 200 mA output current capability can also drive an automotive relay.
- **CONTROL 1:** Terminal programmable on the bitDrive software to activate one command among source change, memory change, volume change, enable/disable Final tuning EQ. This command is activated once the the terminal is connected to a +12 V signal. Please, read the [section 4.16 TRIGGER](#) for more informations.
- **CONTROL 2:** Terminal programmable on the bitDrive software to activate one command among source change, memory change, volume change, enable/disable Final tuning EQ. This command is activated once the the terminal is connected to a +12 V signal. Please, read the [section 4.16 TRIGGER](#) for more informations.

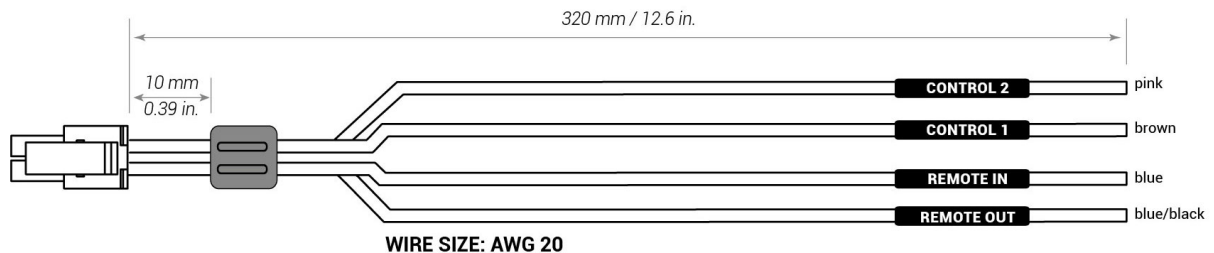

3. SPEAKER OUT

The AF M5.11 bit is supplied with a 8-pole cable to which up to 4 output channels 100W x 4 @ 4Ω + 600W x 1 @ 2Ω can be connected.

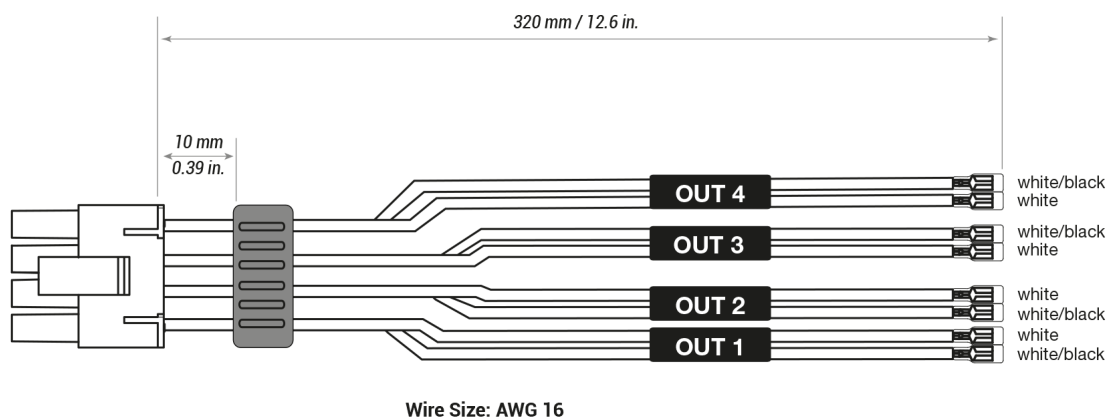

Example of SPK OUT connection

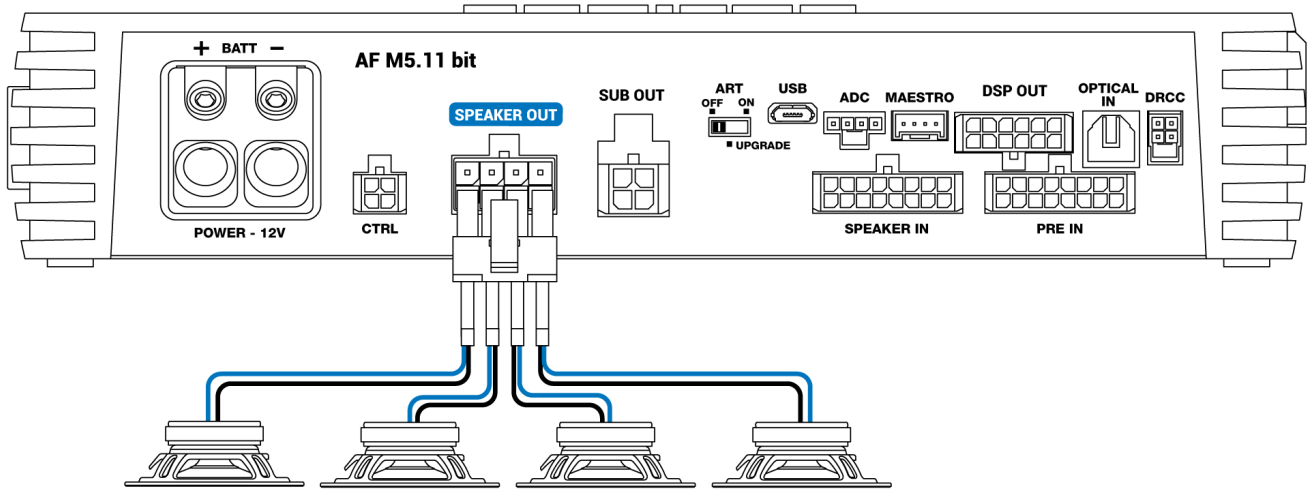

The output channels can be configured by bit Drive software. Each channel features:

- parametric EQ with 15 poles;
- crossover with 68 frequency steps and filters Butterworth or Linkwitz - Riley with slope in the range 6 ÷ 24 dB;
- digital time delay correction;
- phase inversion;
- channel level control in the range 0 ÷ -40 dB;

Moreover, it is possible to use each pair of channels (except for the dedicated SUB channel) in Bridge mode to increase the power rating.

CH 1 ÷ CH 4 AMPLIFIED OUTPUT CHANNELS CONFIGURATION

POWER CHANNEL CONFIG	
STEREO MODE	BRIDGE MODE
CH1 100 W @ 4 Ω / 150 W @ 2 Ω CH2 100 W @ 4 Ω / 150 W @ 2 Ω	CH1+ / CH2- 300 W @ 4 Ω
CH3 100 W @ 4 Ω / 150 W @ 2 Ω CH4 100 W @ 4 Ω / 150 W @ 2 Ω	CH3+ / CH4- 300 W @ 4 Ω

4. SUB OUT

Power output with LO PASS filter, optimized to drive a single voice coil or dual voice coil subwoofer, or two subwoofers.

SUB AMPLIFIED OUTPUT CHANNEL

SUB OUT MODE

SUB 400 W @ 4 Ω / 600 W @ 2 Ω

Example 1: Connection to a single voice coil subwoofer (minimum 2 Ω):

It is suggested to put in parallel the SUB OUT+ and SUB OUT- outputs to get more current rate.

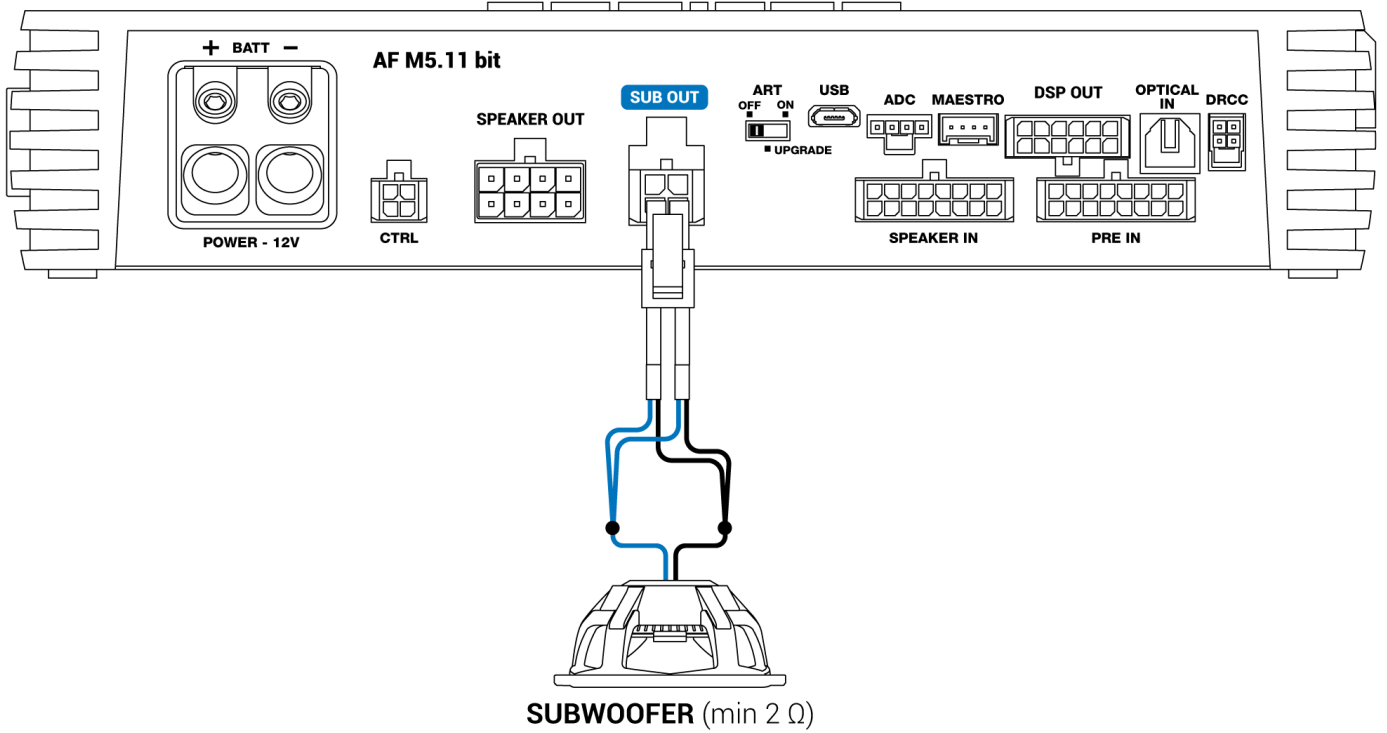

As alternative, one single SUB OUT+/- output of your choice can be used.

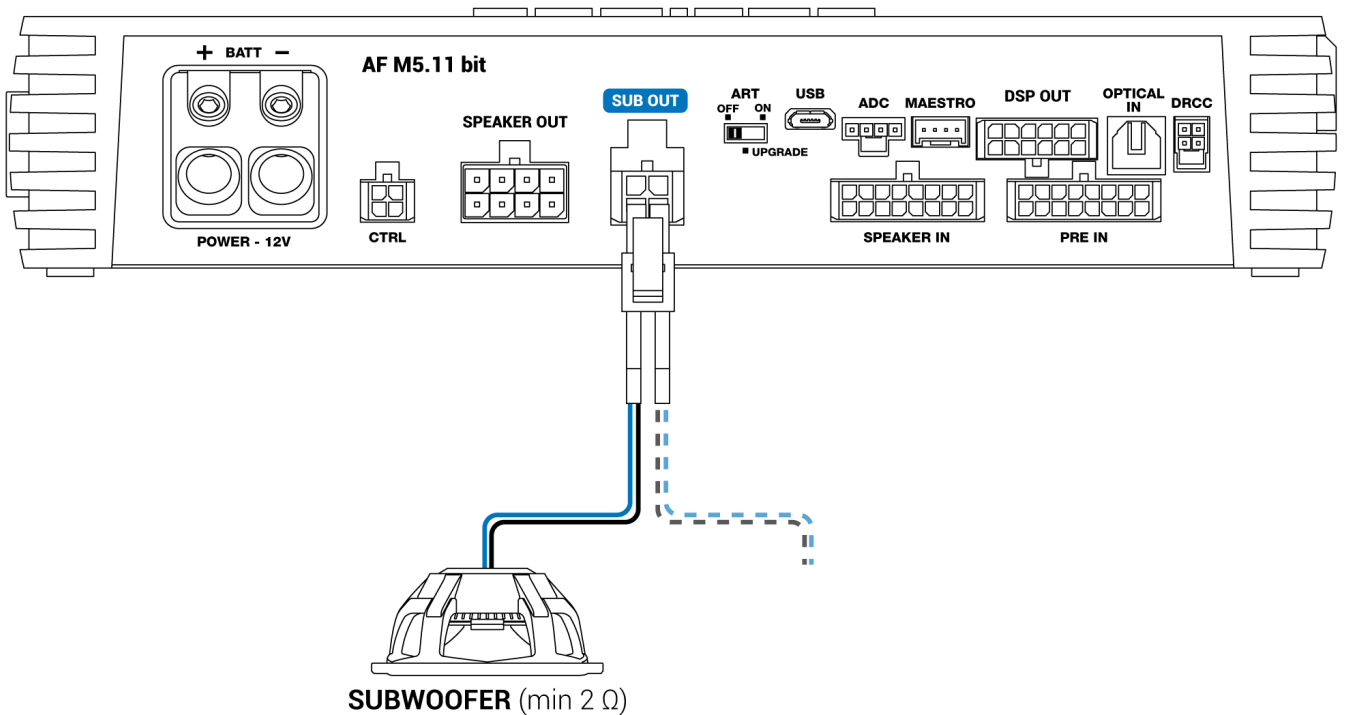

Example 2: Connection to dual voice coil subwoofer (minimum 4 Ω)

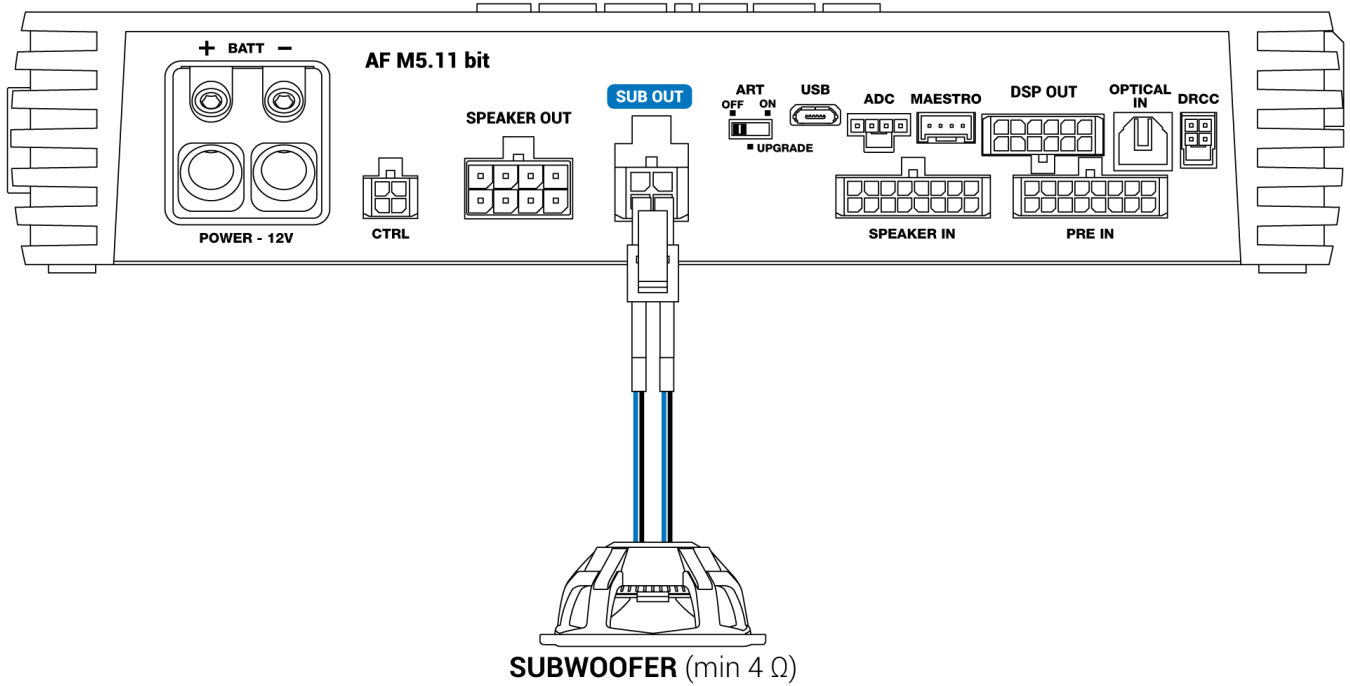

Example 3: Connection to two subwoofers (minimo 4 Ω)

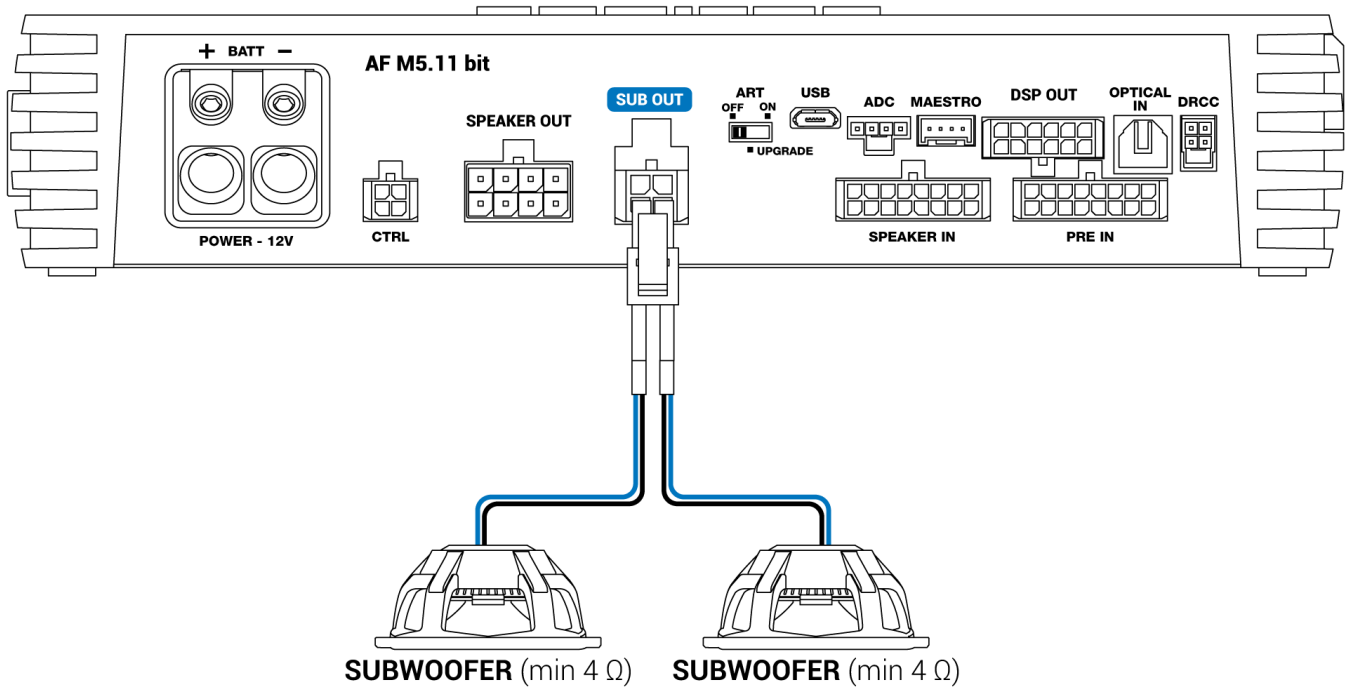

5. SPEAKER IN

Connector for High-level inputs signals and product turn on:

AF M5.11 bit is provided with a 16 poles multipolar connector to which up to a maximum of 8 high-level input channels can be connected. This port allows using the amplifier automatic turn on function (ART)



UPGRADE

by high-level input signal ([See point 13. ART – UPGRADE](#)). This input accepts signals coming from an

amplified source with a voltage level between 2.2 and 22 V RMS. It is also possible to increase the number of high-level inputs with the F4IN accessory. This board adds 4 input channels, such that the amplifier can manage 12 input channels in total ([See point 16. SLOT FOR ADDITIONAL MODULES](#)).

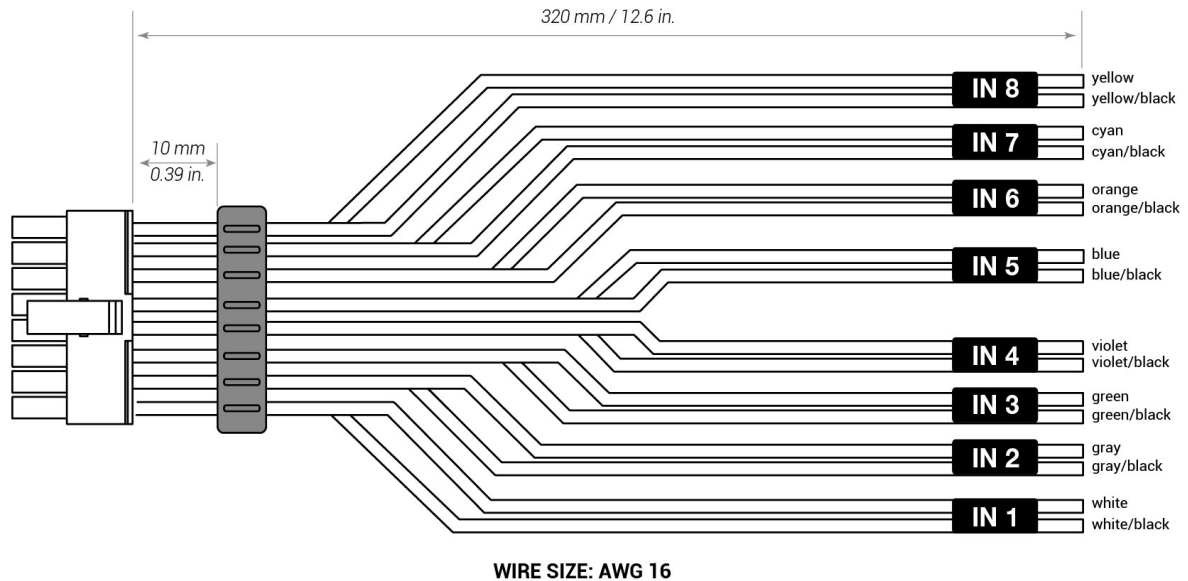

The channels CH1 and CH2 feature the AUTO TURN ON (ART) function for automatic turn on/off of the amplifier thanks to the connection to the source high-level signals. This function can be enabled or disabled via the ART switch on the amplifier front panel.

Example 1. SPEAKER INPUT: 2 WAY FRONT + REAR

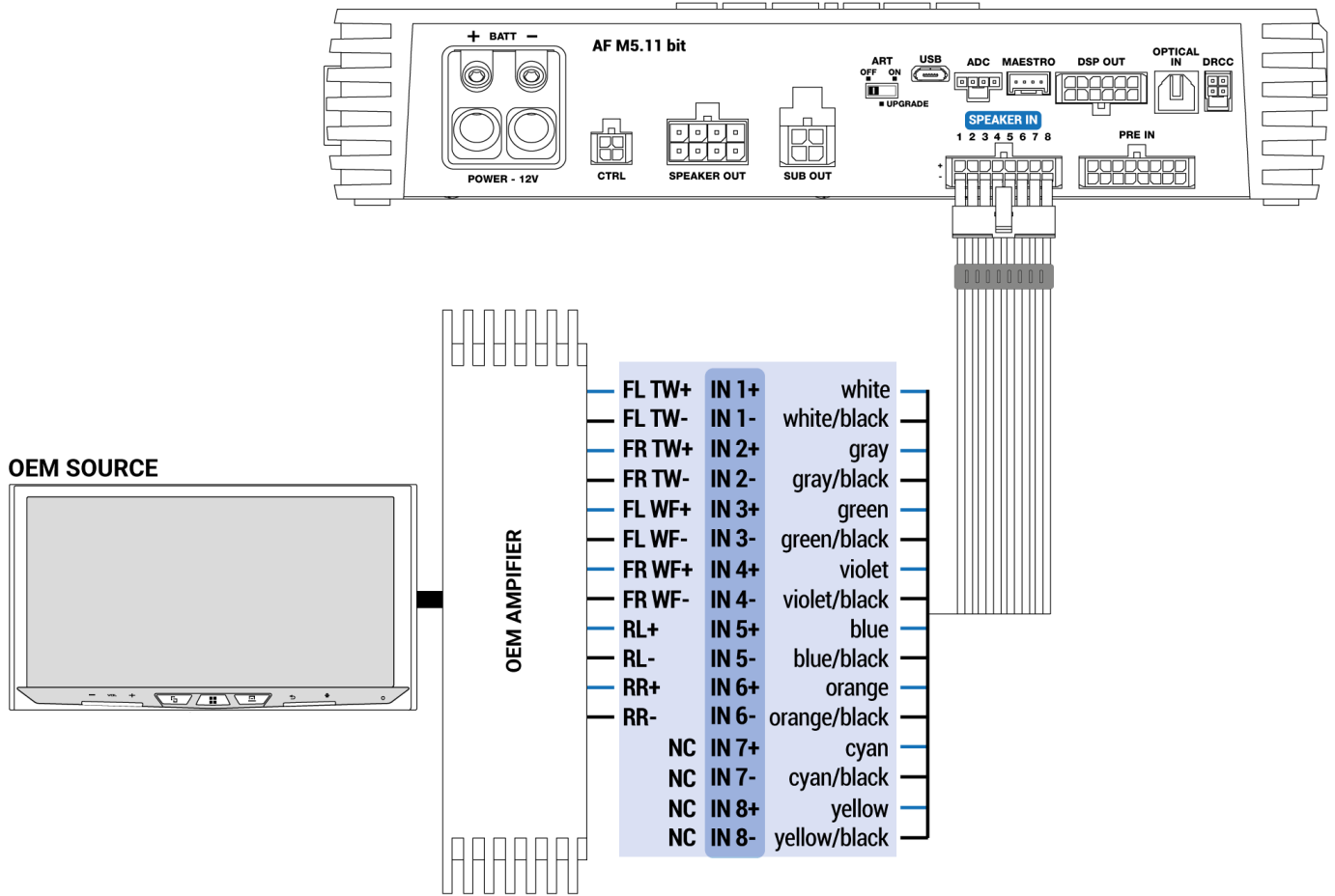

Example 2. SPEAKER INPUT: 2 WAY FRONT + REAR + CENTER + SUB

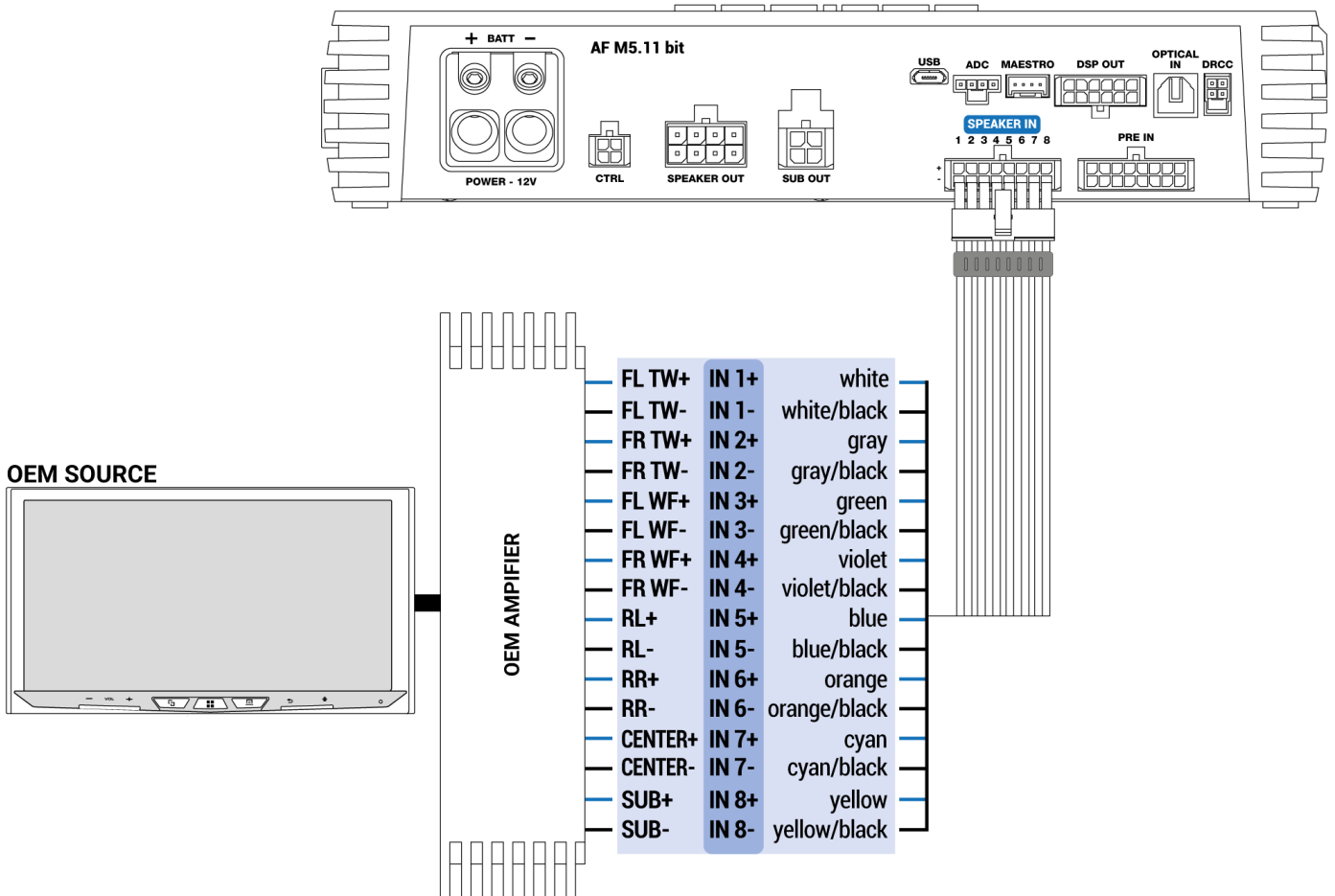

Example 3. SPEAKER INPUT: 2 WAY FRONT + 2 WAY REAR

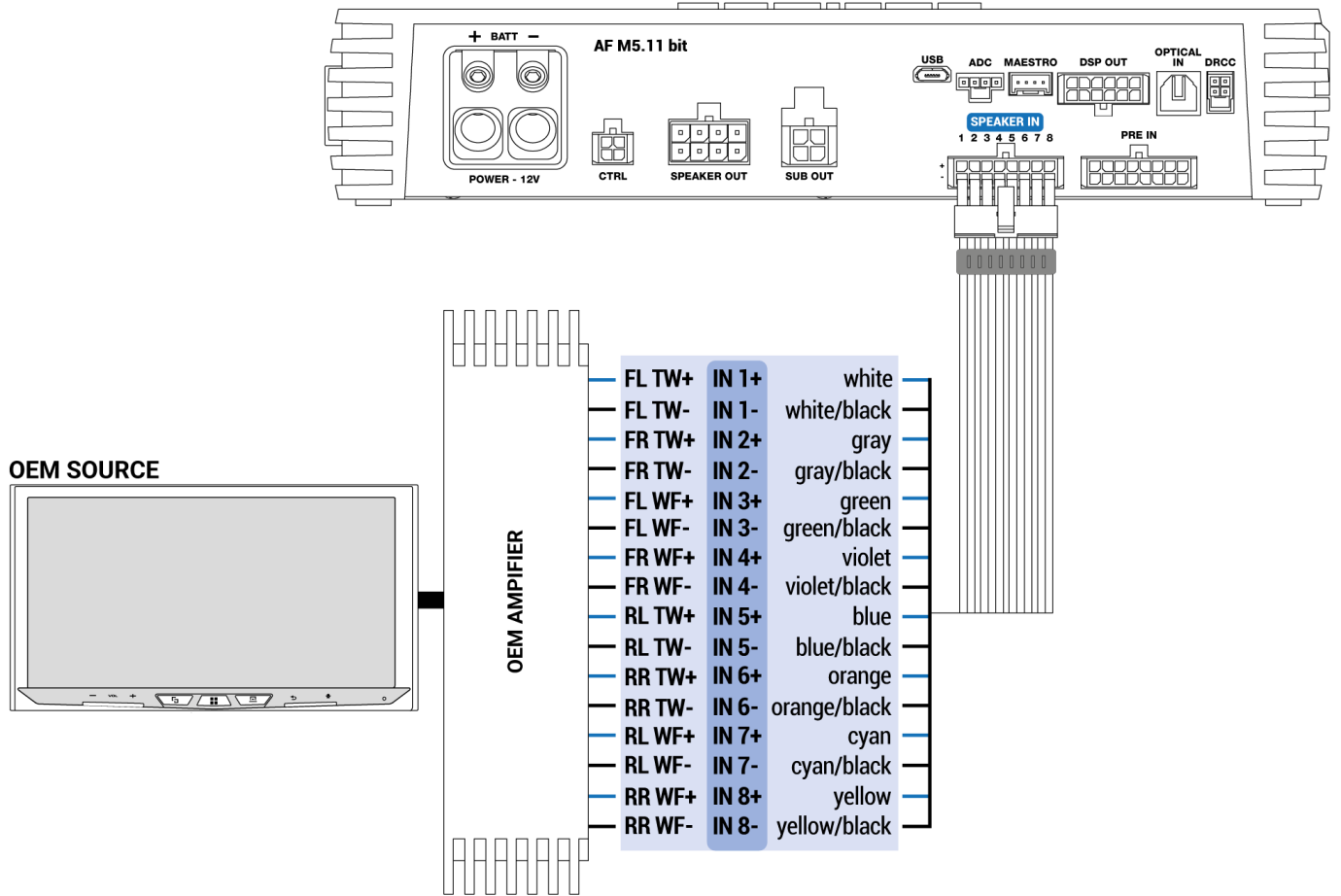

Example 4. SPEAKER INPUT: FRONT + CENTER + REAR + 2 SUB

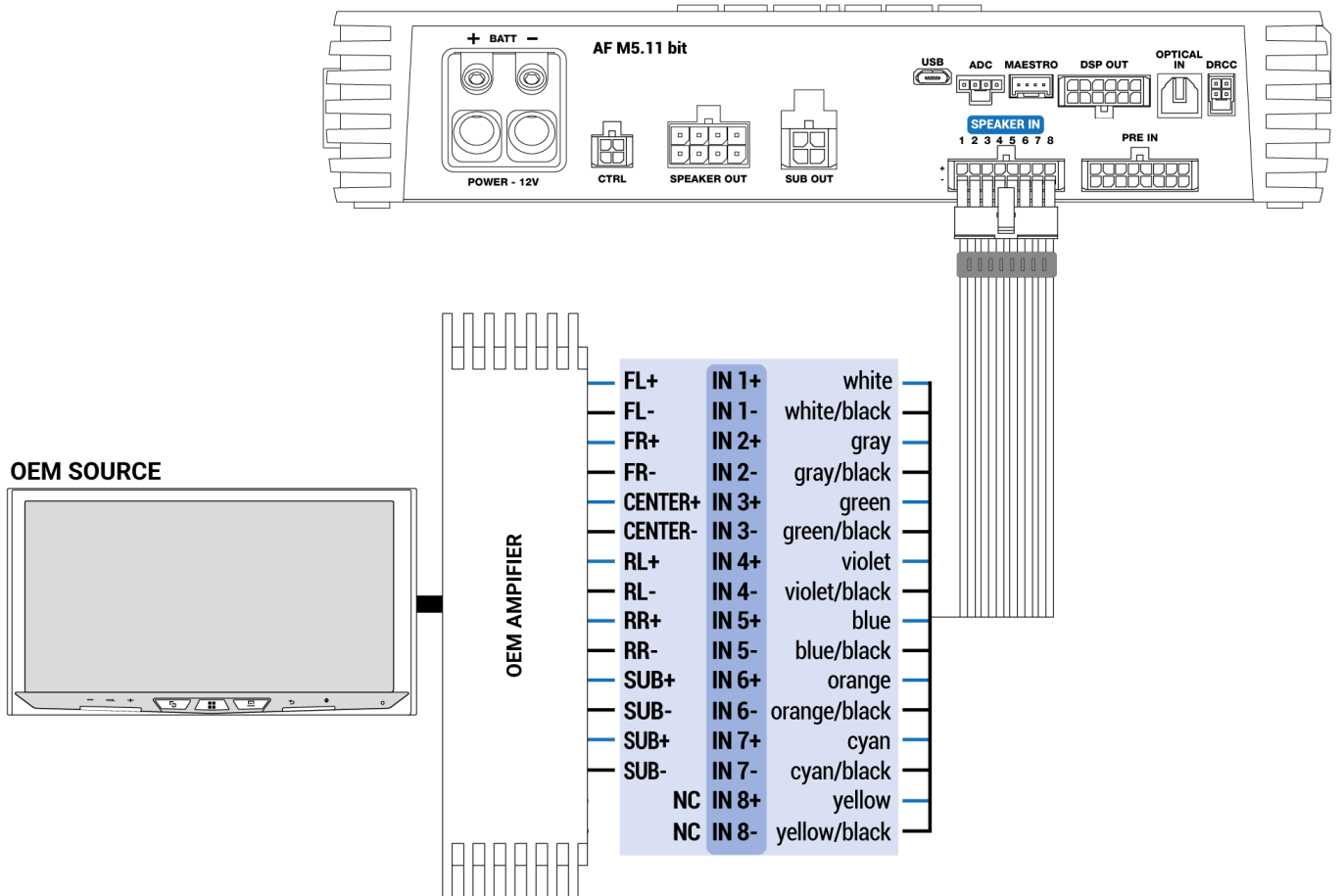

Example 5. SPEAKER INPUT: 3 WAY FRONT + REAR

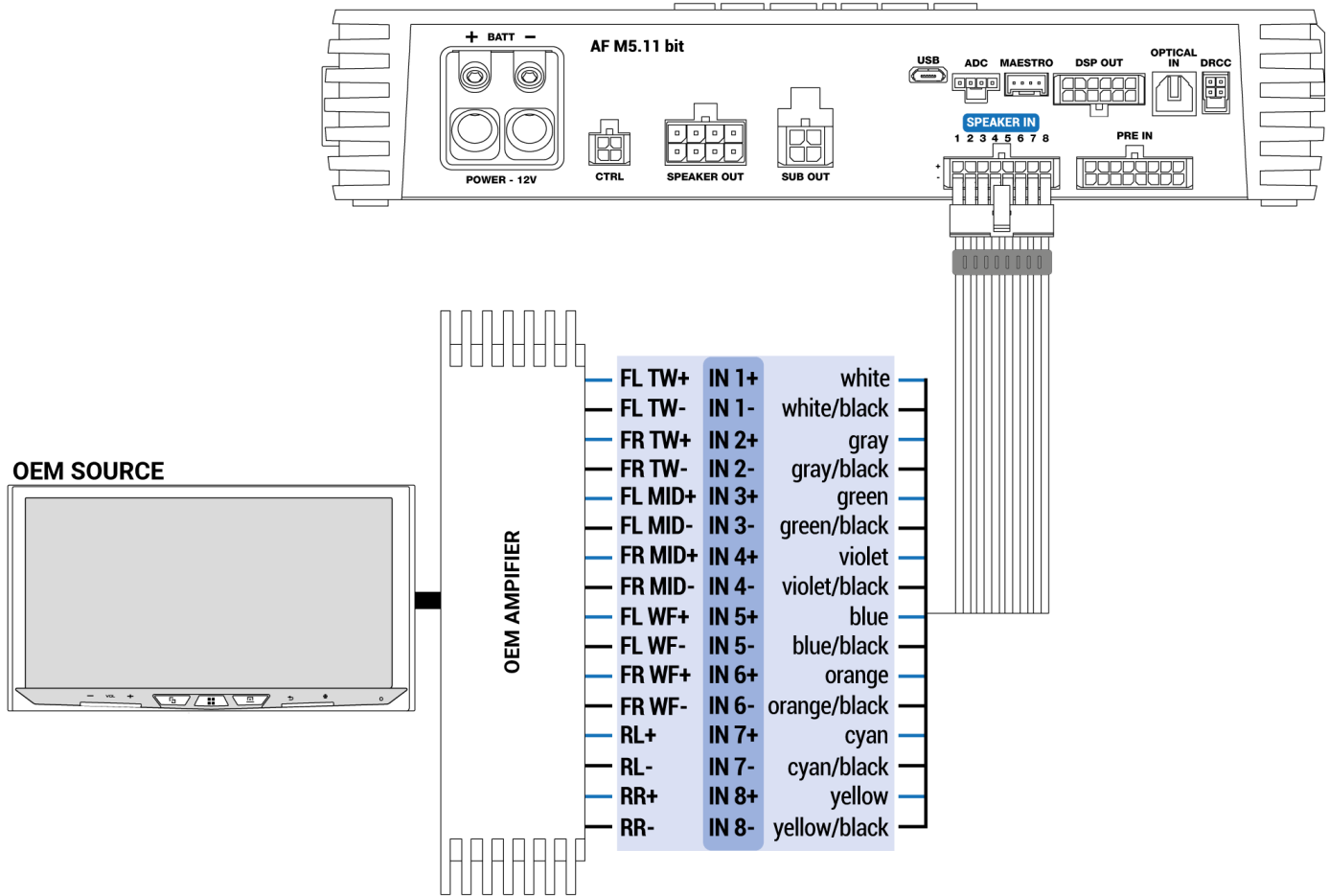

6. PRE IN

AF M5.11 bit is provided with a cable featuring RCA connectors that can connect up to a maximum of 8 low level input channels. This input accepts signals from a pre-amplified source, the signal to be applied must have a level between 0.6 and 6 V RMS.

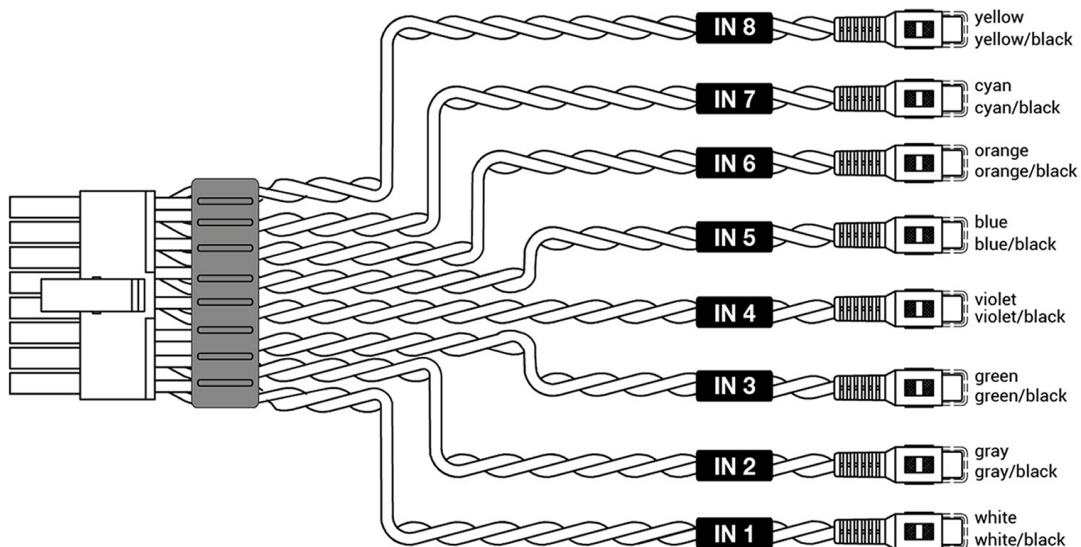

Example 1. PRE INPUT: FRONT + REAR + CENTER + SUB

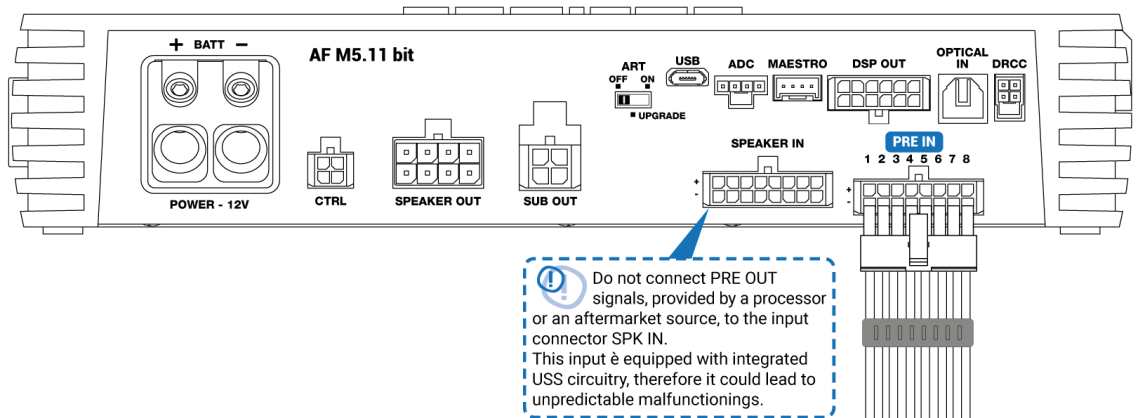

AFTERMARKET SOURCE

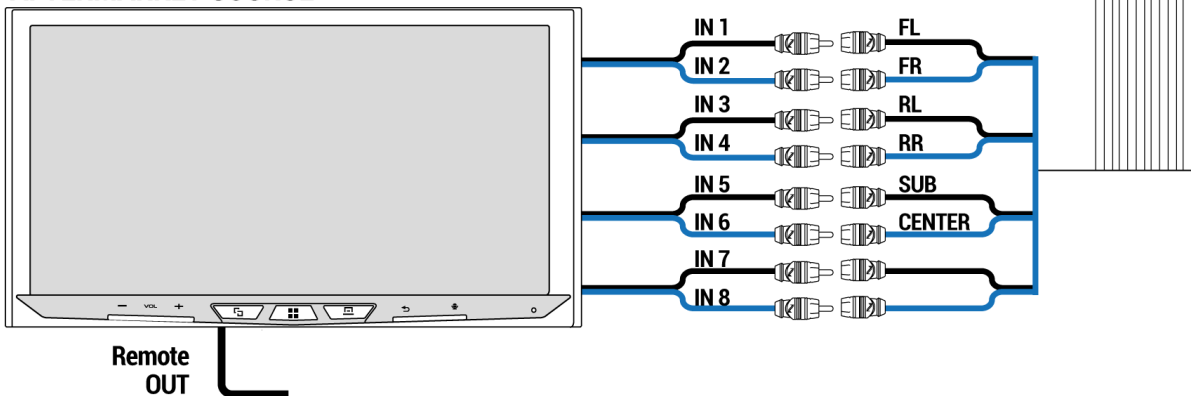

Example 2. PRE INPUT: 2 WAY FRONT + REAR + CENTER + SUB

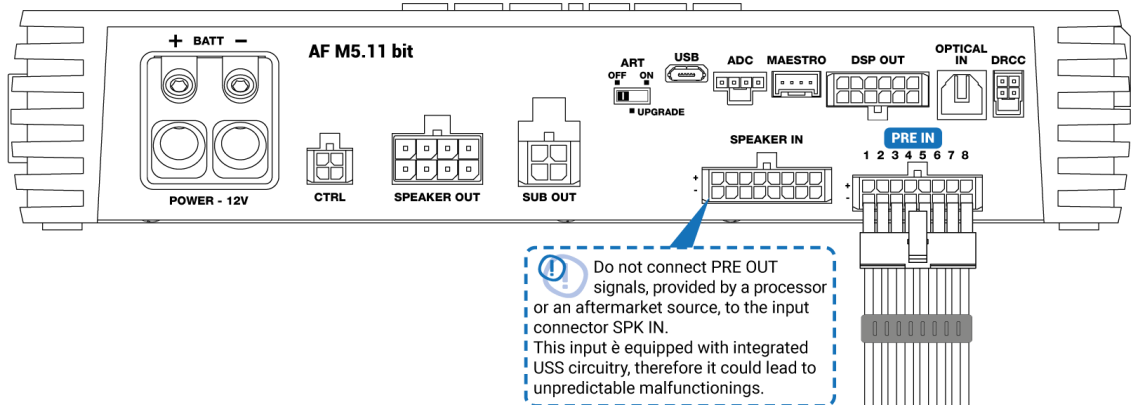

AFTERMARKET SOURCE

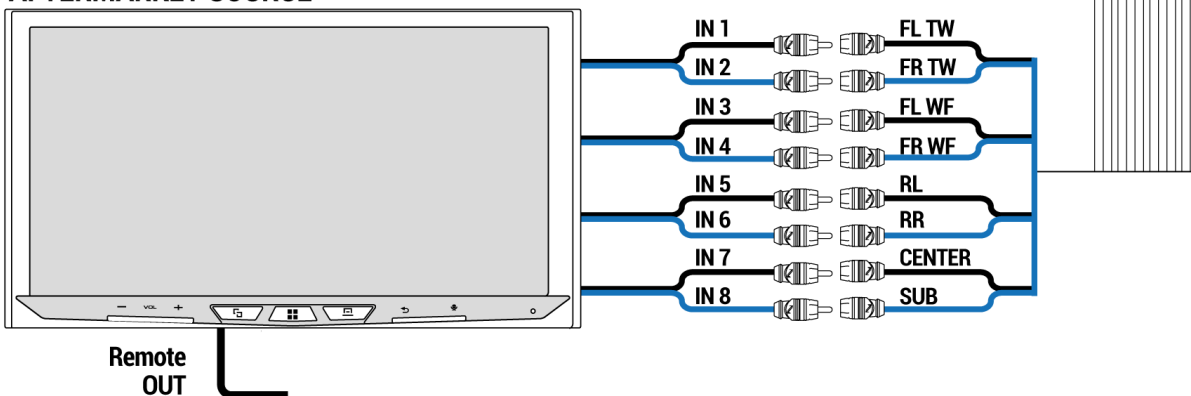

7. DRCC

Port for DRC AC (optional) connection. The DRC AC allows the remote control of the AF C8.14 bit main functions. For more informations please read [4.18 DRC AC](#).

Turn On/off the AF C8.14 bit by DRC AC

lightly push the DRC AC knob (turn ON). With a long press on the DRC AC knob (turn OFF). In this case, no other connections are required for turn on the device.

Note: if the amplifier has been turned on by REM IN wire, it can be turned off only by the same REM IN. Instead, if the amplifier has been turned on by DRC AC, then it can be turned off by either DRC AC or REM IN signal.

8. OPTICAL IN

Digital optical S-PDIF input.

The **AF M5.11 bit** accepts at its input PCM signals up to 192 kHz / 24 bit sampling frequency rate. So DOLBY DIGITAL (AC3) multi-channel signals coming from audio/video sources (such as the audio of a film in DVD) or DTS can not be reproduced. Connect a fiber optic cable with a TOSLINK connector. This input can be selected using the external control DRCC or by activating it using the control terminal ([see sec. 7.3.2](#)) appropriately configured. An additional digital input, optical S-PDIF or electrical S-PDIF can be added to AF M5.11 bit, using the F2O expansion module, bringing the available digital inputs to two ([See point 16. SLOT FOR ADDITIONAL MODULE](#)).

8.1 HOW TO SELECT THE OPTICAL INPUT

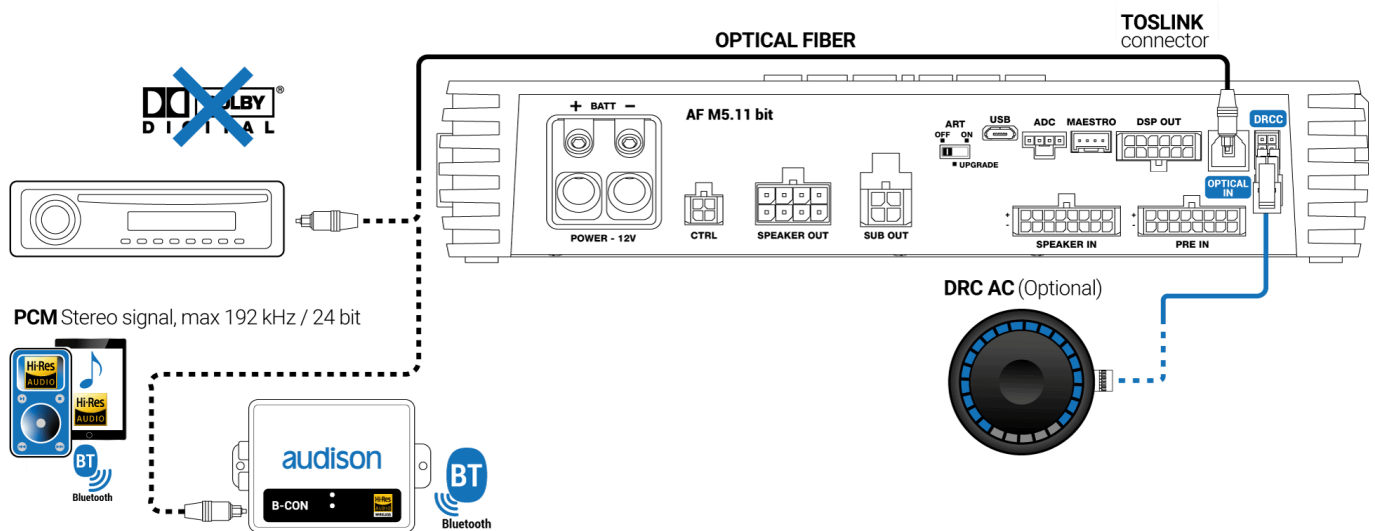

WARNING: the digital input accepts up to 192 kHz / 24 bit stereo PCM signals. So DOLBY DIGITAL (AC3) multi-channel signals coming from audio/video sources (such as the audio of a film in DVD or DTS can not be reproduced). The output of these devices will therefore have to be set in STEREO mode for the signal to be reproduced.

How to select the OPTICAL input:

1. Using the DRC AC, selecting the OPTICAL input.
2. Using one of the "CONTROL" terminals properly set (see sec. 7.3.2). This command is active connecting the terminal to + 12V.
3. Using the PC Software.
4. Through ADC port with compatible device.
5. Through MAESTRO port with compatible device.

An additional digital input, optical S-PDIF or electrical S-PDIF can be added to AF C8.14 bit, using the F20 expansion module, bringing the available digital inputs to two (see point [16. SLOT FOR ADDITIONAL MODULES](#)).

9. DSP OUT

The AF M5.11 bit features a DSP OUT pre-amplified output, to which the supplied multipolar cable or the AF LINK accessory cable can be connected to have 6 additional channels configurable on the bitDrive software.

- **Examples 1 an 2:** by inserting the AF LINK cable the AF M5.11 bit DSP OUT can be connected to one or more Audison AF D amplifiers (models without DSP), to extend the audio system up to 11 outputs.
- **Example 3:** if the AF LINK cable is not available, it is still possible to connect the AF M5.11 bit DSP OUT to one or more Audison AF D amplifiers (models without DSP), by cutting and properly soldering the supplied cable with compatible Molex connectors.
- **Example 4:** if another amplifier with PRE-IN inputs and different from the Audison AF line is used, the supplied DSP OUT cable must be properly soldered with RCA connectors.

WARNING: It is recommended to check the input signal levels to be compatible with the DSP OUT output levels.

AF LINK cable

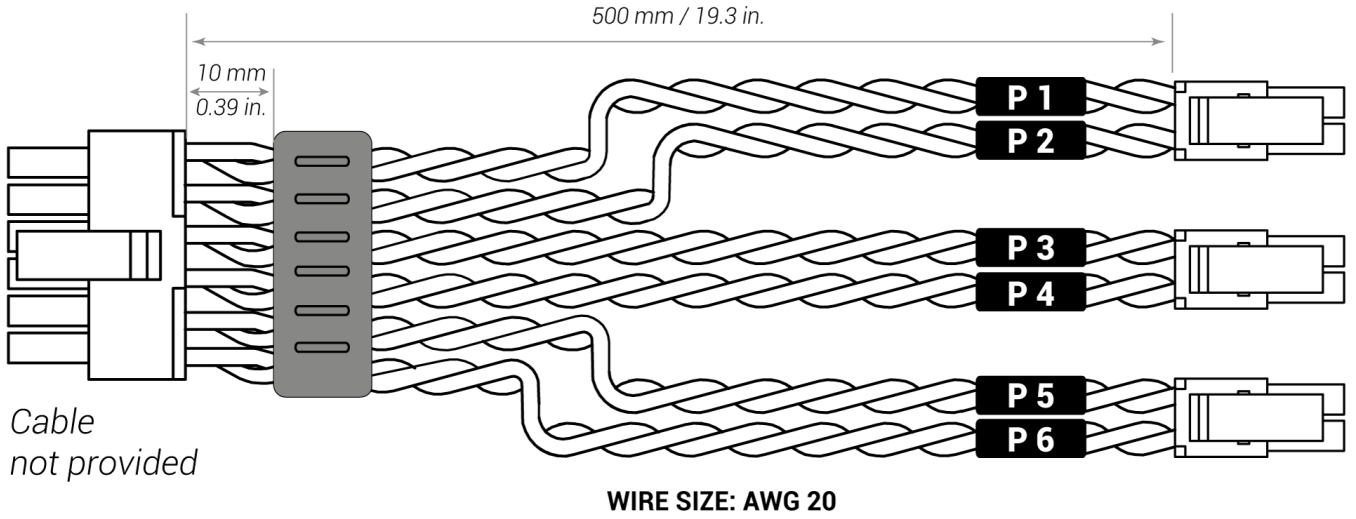

Example 1

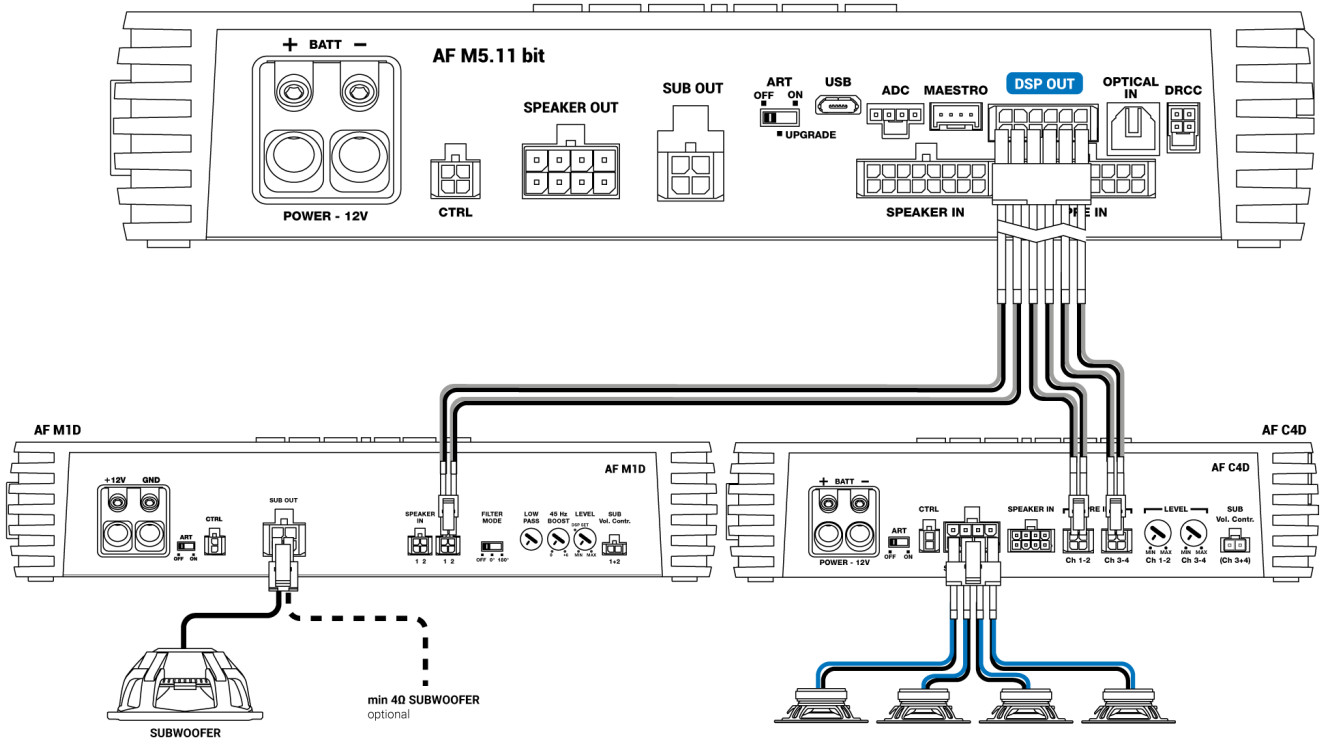

Example 2

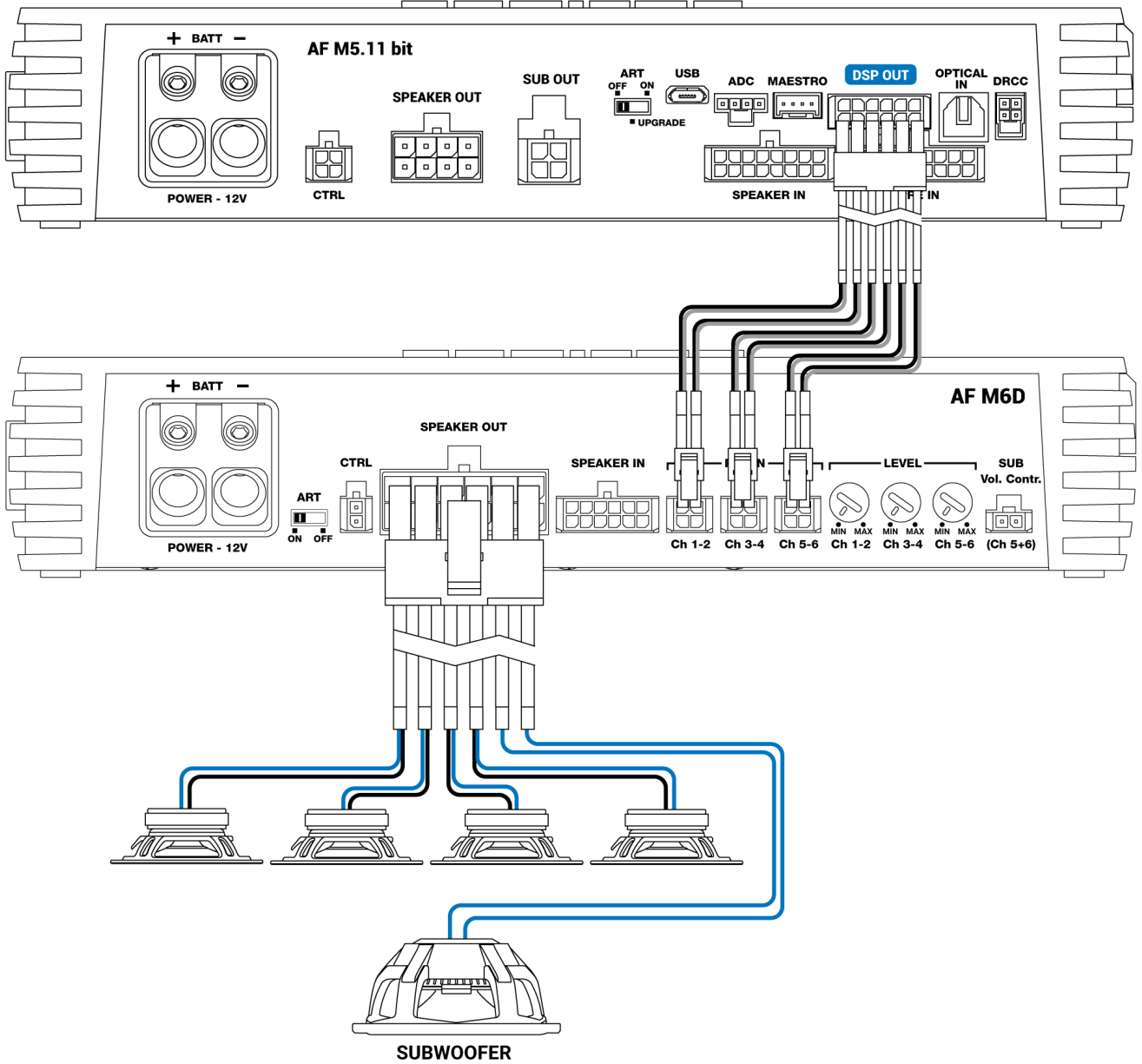

Example 3

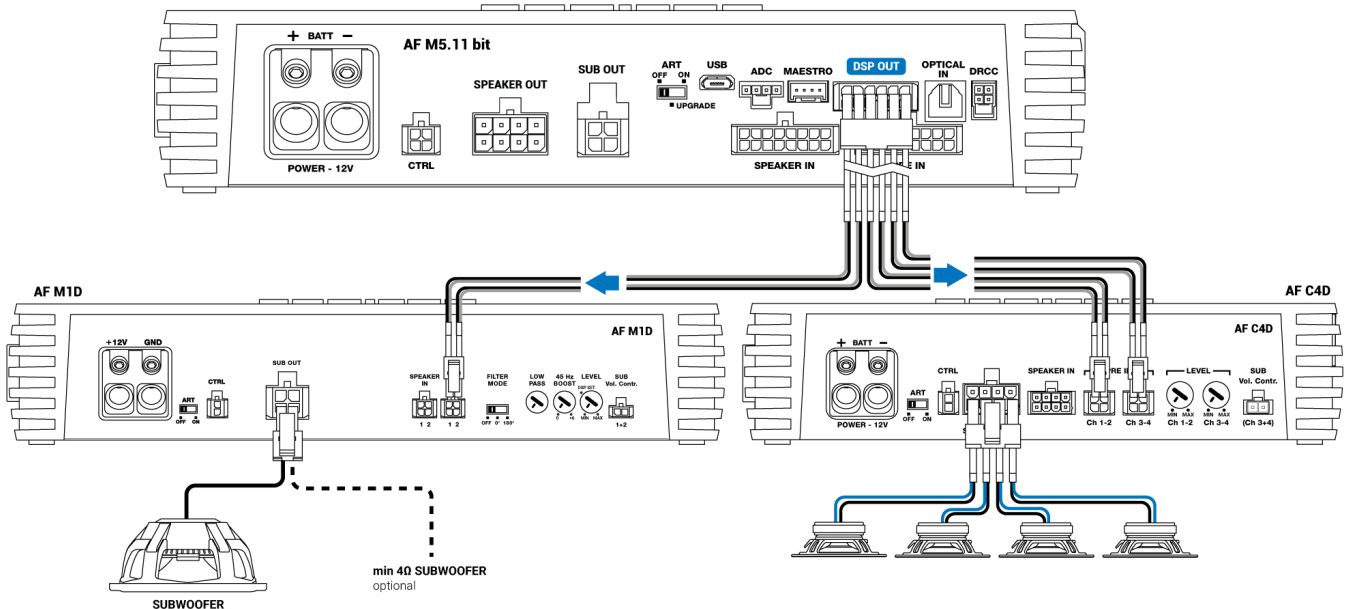

Example 4

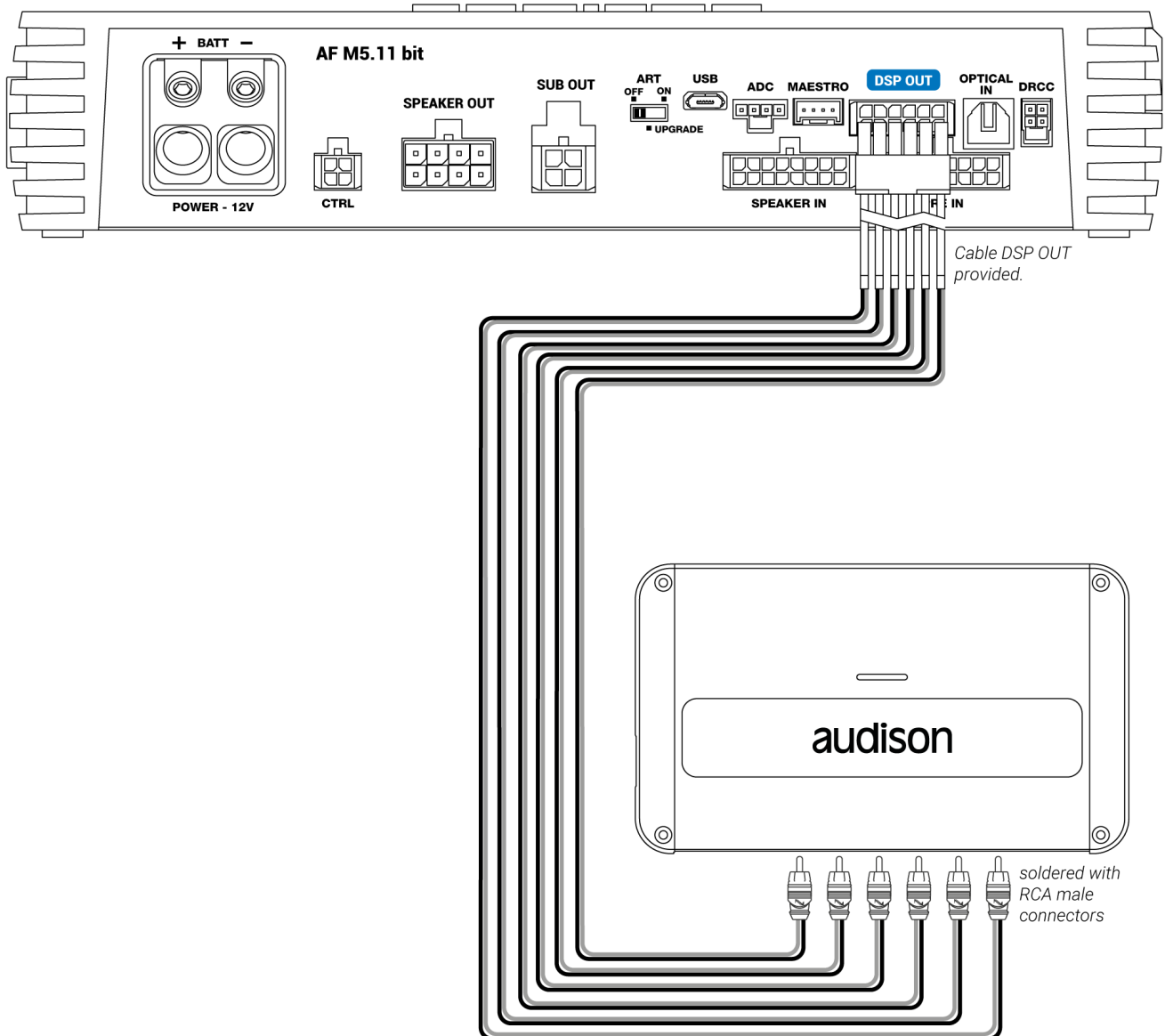

10. MAESTRO

Dedicated port for communication with Maestro AR devices.

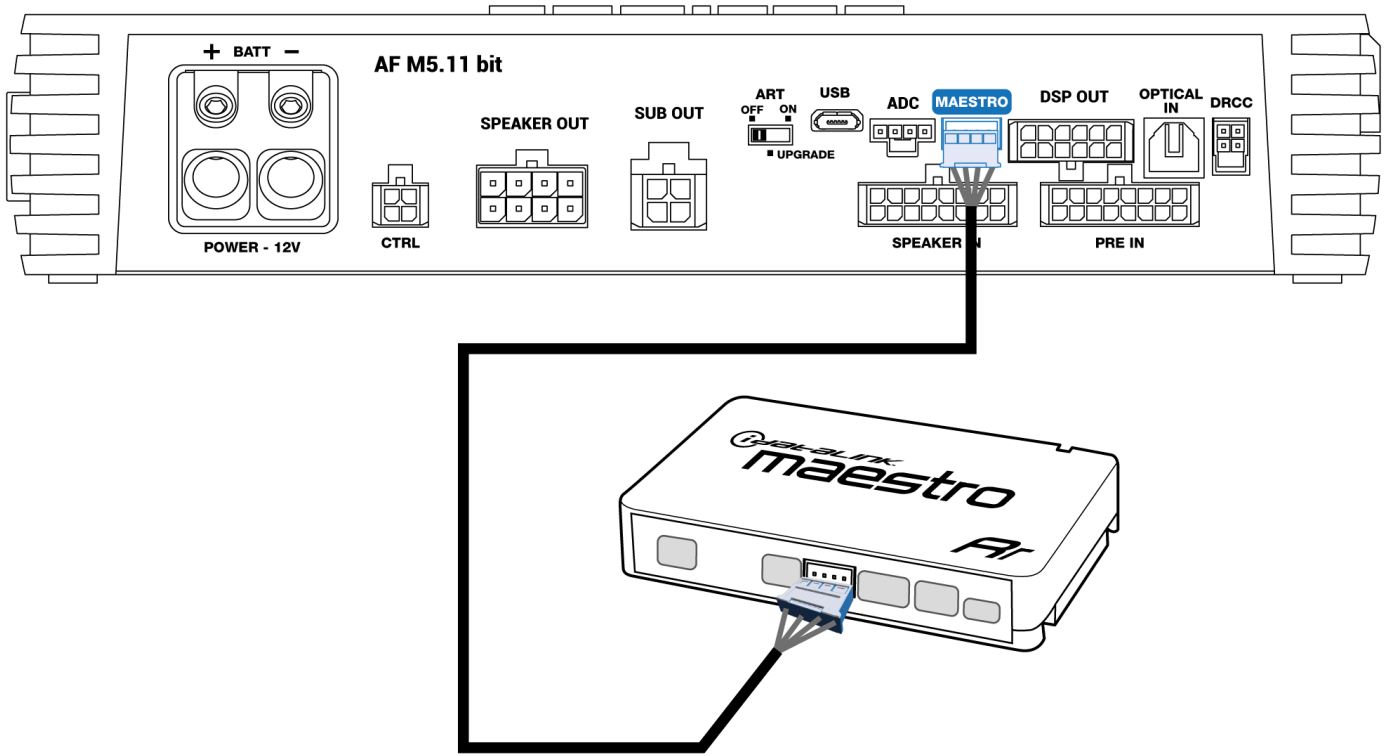

11. ADC (Audison Data Control)

Port for serial communication with external compatible devices (ex. B-CON).

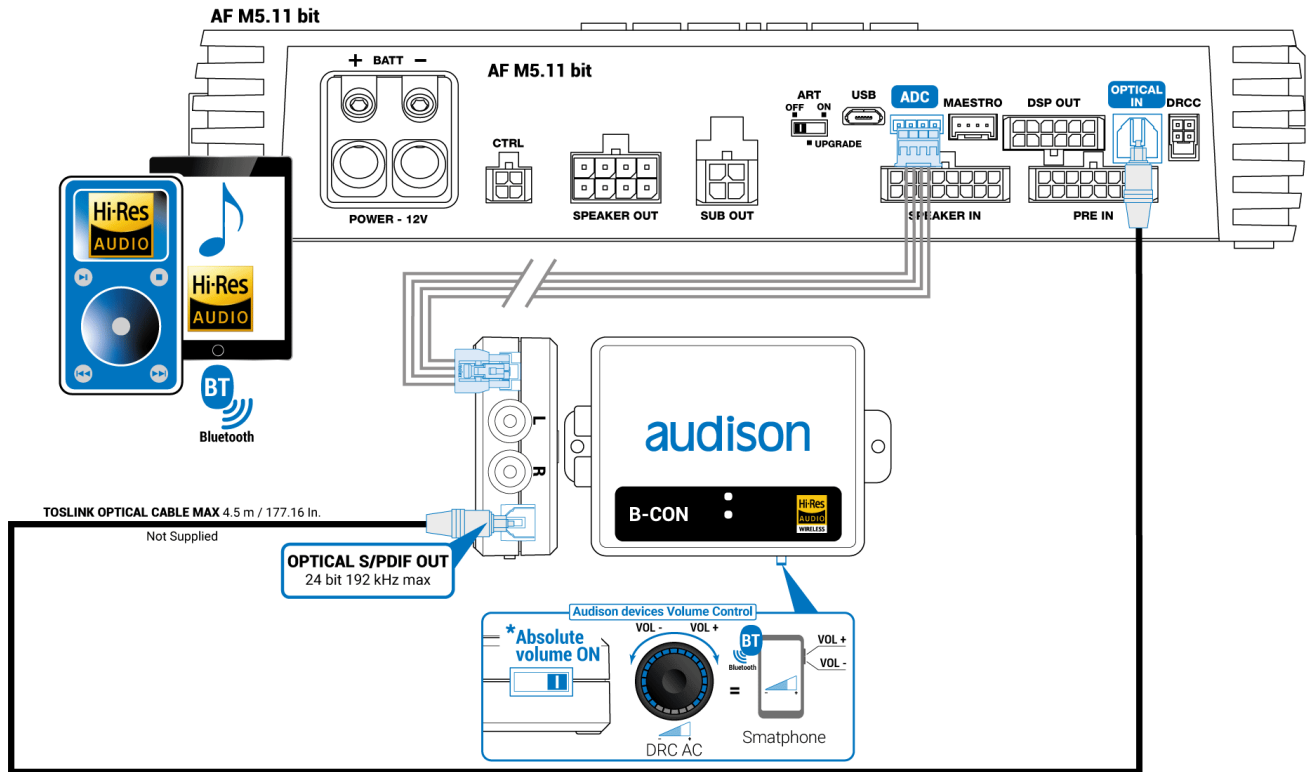

12. USB

USB (micro) connection to connect the product to a PC in order to manage the functions using AF M5.11 bit software. The connection standard is USB 2.0/3.0 compatible.

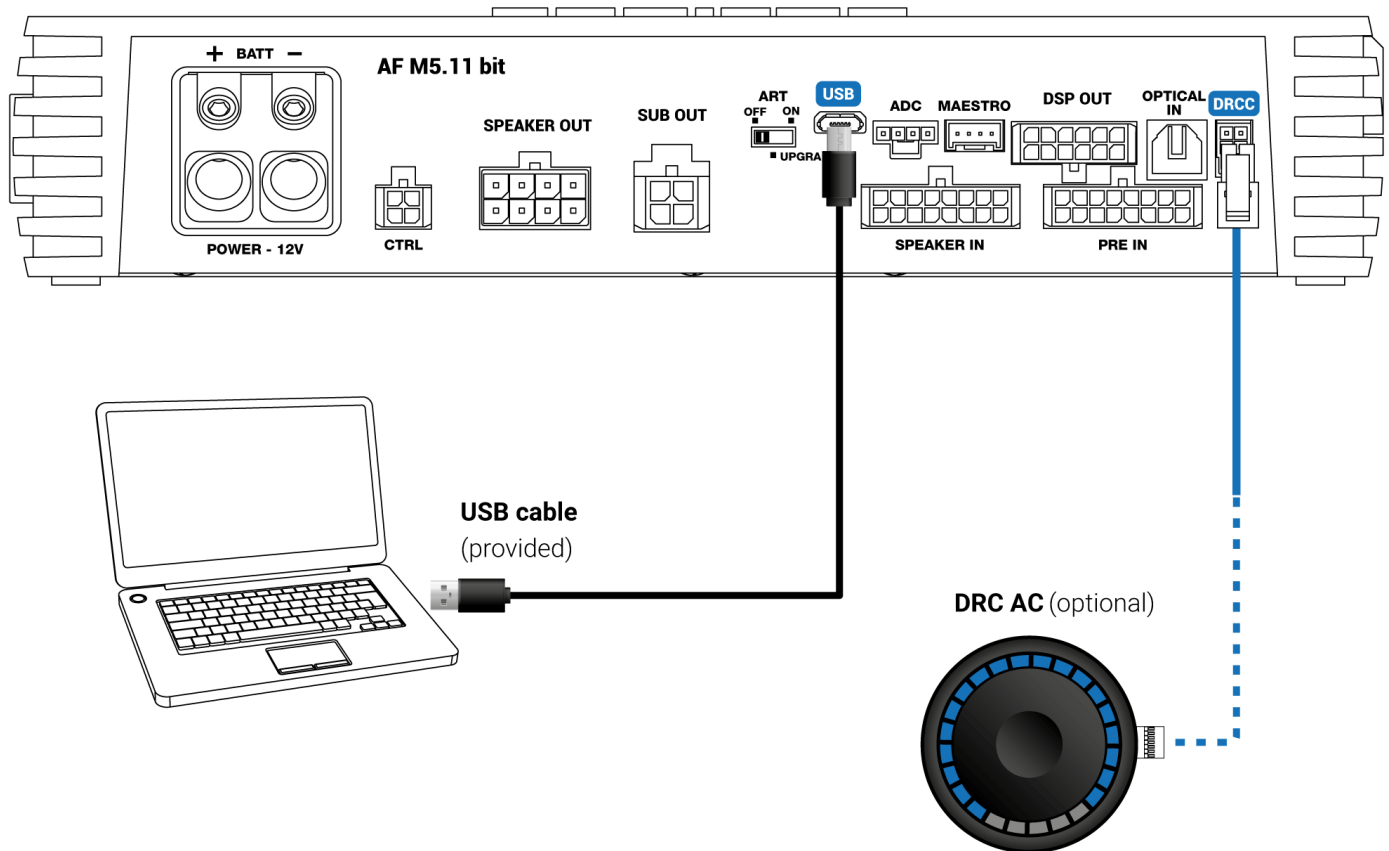

13. ART (Automatic Turn ON) - UPGRADE

- **Switch in ON position:** it allows to turn on the device from the MASTER "SPEAKER IN" input (ART ON function).
- **Switch in OFF position:** it allows to disable the device turn on from the MASTER "SPEAKER IN" input (ART OFF function).
- **Switch in UPGRADE position:** this mode allows to turn on the amplifier in recovery mode (Rescue Mode) in case it was stuck due to a wrong firmware upgrade process.

WARNING: it is suggested to use this mode only in case of product in stuck state. In this mode the PC software is not accessible.

14. FUSE

2 Blade type protection fuse 30 A. In case you need to replace the product fuse, use only the same type and value as the original.

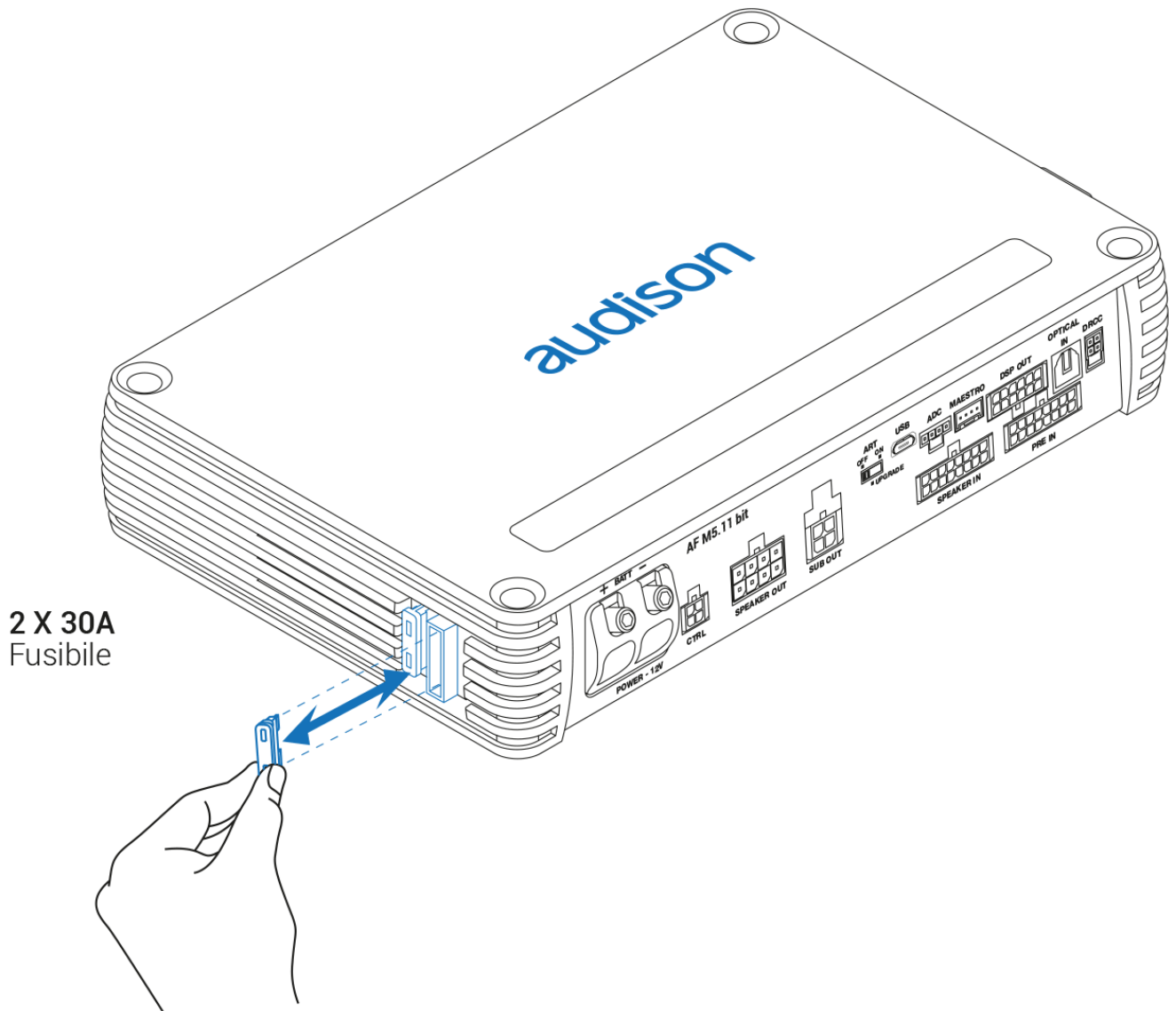

15. LOGO

AF M5.11 bit is provided with a built-in control that manages its status and protects the circuits and connections to the speakers. Any product malfunctions can be visually informed by the logo placed above the amplifier.

A BLUE logo means:

AF M5.11 bit is on.

Slow flashing BLUE logo means:

Product being switched ON/OFF (no audio signal on outputs).

Quick flashing BLUE logo means:

Product being switched ON/OFF (no audio signal on outputs).

RED logo on means:

Intervention of the DC protection. Contact the authorized technical assistance service.

RED flashing logo "1 Sec. ON / 1 Sec. OFF" means:

- AF M5.11 bit temperature reached 75° C and the thermal protection was triggered. It will start operating again at around 70° C.

RED flashing logo “½Sec. ON / ½Sec. OFF” means:

- Output overload. The red LED flashes when the output load goes below the minimum allowed capacity of about 2Ω impedance. The LED comes on without flashing, activating the protection. When listening to music, if the acoustic reproduction stops for a few seconds, check if the amplifier red LED is flashing. This means there was an overload. Turn the amplifier off and check the speakers and wirings. This protection is self-restoring.
- Speaker wiring anomaly. The red LED flashes when a terminal on the speaker goes in short-circuit with the vehicle chassis. When listening to music, if the acoustic reproduction stops for a few seconds, check to see if the red amplifier LED is flashing; this means there was a short circuit between a terminal on a speaker and the vehicle chassis. Turn off the amplifier and check the speakers and wiring. This protection is self-restoring.

RED flashing logo “¼Sec. ON / ¼ Sec. OFF” means:

- OVER VOLTAGE” protection activation, due to the fact that the battery voltage is higher than 17V. The product will turn off after 3 minutes.

WARNING: check the state of charge of the car alternator.

16. SLOT FOR ADDITIONAL MODULES

AF M5.11 bit includes 2 additional optional accessories (F4IN / F2O) to be inserted individually in the appropriate housing on the right side of the product by removing the screws and the panel.

IMPORTANT: follow these steps for a proper installation of the F4IN or F2O accessory board:

1. **Turn off the amplifier;**
 2. **Insert the F4IN or F2O board in the slot;**
 3. **Turn on the amplifier and open the bit Drive software;**
 4. **Warning: if the amplifier already has a setup saved in its memory that was created before inserting the accessory board, this setup will not be compatible with the new hardware configuration and it could not be loaded. If a new setup similar to that is going to be created, save the setup in the PC to check it later on in Offline mode;**
 5. **Open the Settings menu and select the Reset device command to detect correctly the additional channels of the accessory board (read [sect. 2.2](#) of the bit Drive manual for more informations).**
- **F4IN (Forza 4 Input):** it allows to add 4 analog high level input channels (SPK IN), to get a total of 12 high level inputs of the AF M5.11 bit. Connect the **Speaker IN 4CH** cable (included with this module) as shown in image 3.

IMPORTANT: do not connect the source PRE-IN signals to the F4IN module. This connection may damage the source itself.

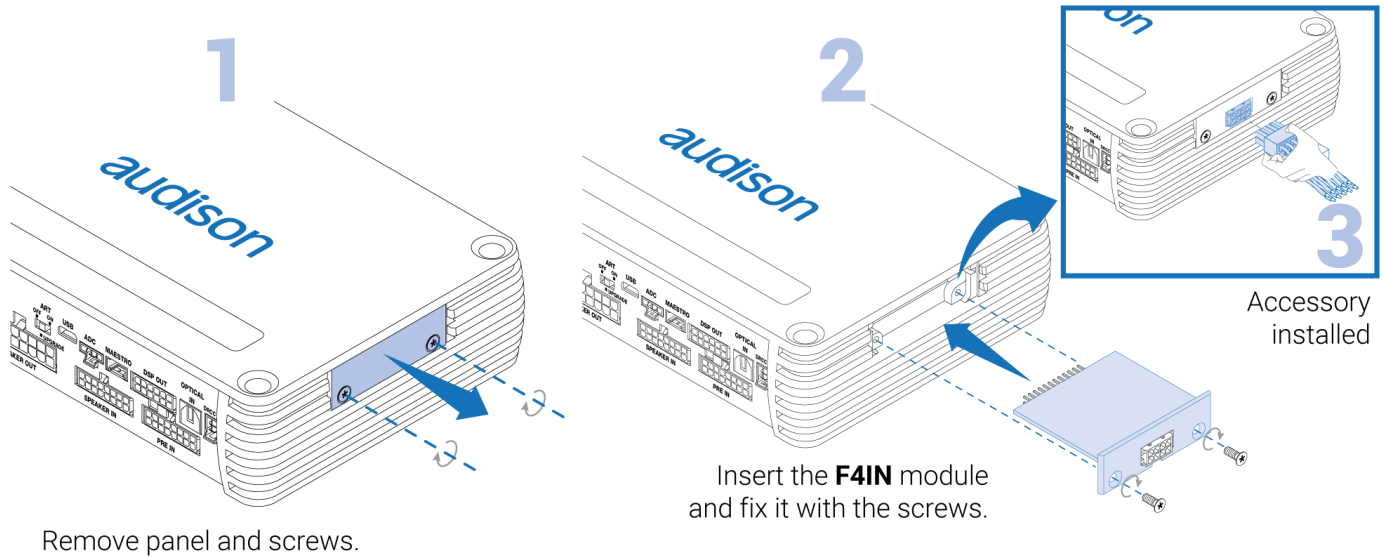

Speaker IN 4CH input cable

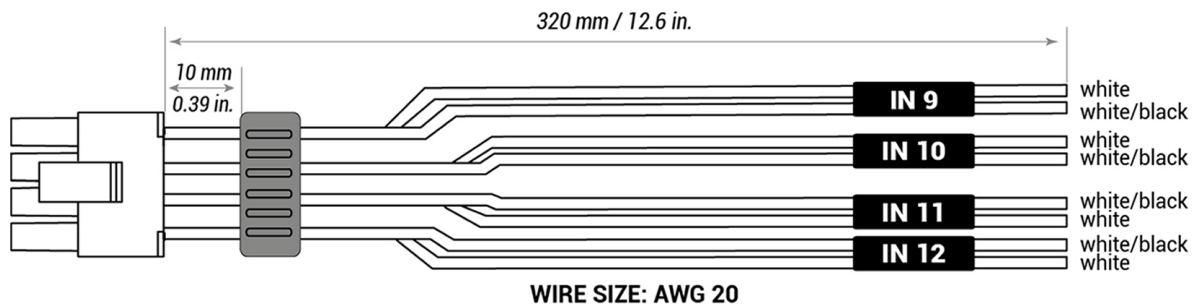

IMPORTANT: with respect to the native 8 SPK IN inputs, the sensitivity scale of the F4IN inputs is $3.2 \div 32$ VRMS, in order to allow the integration in advanced OEM systems that deliver higher voltages. In the bit Drive software the F4IN input channels will always be #9,#10,#11,#12. Please refer to the following table for a correct sensitivity calibration of each F4IN channel.

bit Drive input sensitivity [VRMS]	F4IN applied sensitivity [VRMS]
22	32
21,3	31
20,5	29,8
19,8	28,8
19,1	27,8
18,3	26,6
17,6	25,6
16,9	24,6

16,1	23,4
15,4	22,4
14,7	21,4
13,9	20,2
13,2	19,2
12,5	18,2
11,7	17
11	16
10,3	15
9,5	13,8
8,8	12,8
8,1	11,8
7,3	10,6
6,6	9,6
5,9	8,6
5,1	7,4
4,4	6,4
3,7	5,4
3,3	4,8
2,9	4,2
2,6	3,8
2,2	3,2

▪ **F2O (Forza 2 Optical):** Adds a second digital S-PDIF coaxial or optical input (192 kHz/24 bit max.), selectable by the dedicated switch. **COAXIAL input cable** (included with this module) as shown in image 3.

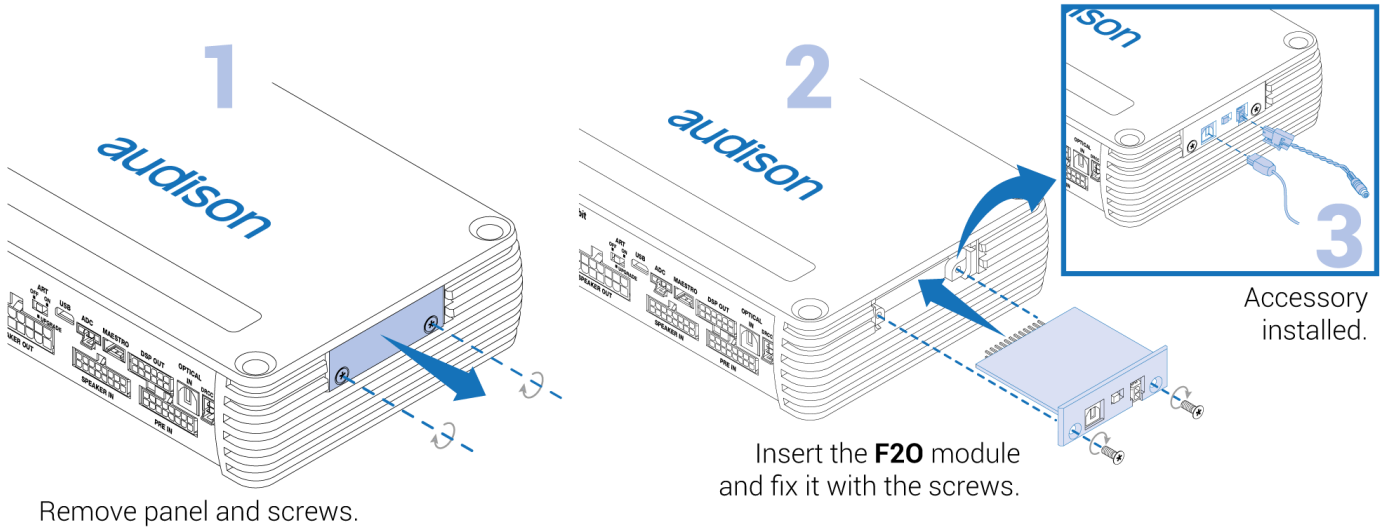

IMPORTANT NOTE: the Absolute Volume function is not available on this module. Therefore, in case of use of a B-CON or accessories compatible with that function, it is recommended to use the main optical input of the AF M5.11 bit [\(see point 8. OPTICAL IN\).](#)

COAXIAL input cable:

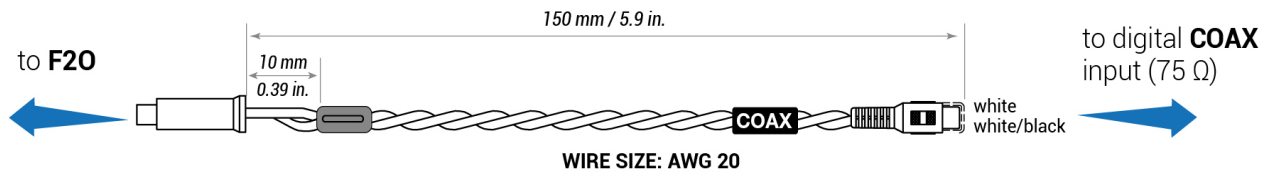

Example of use

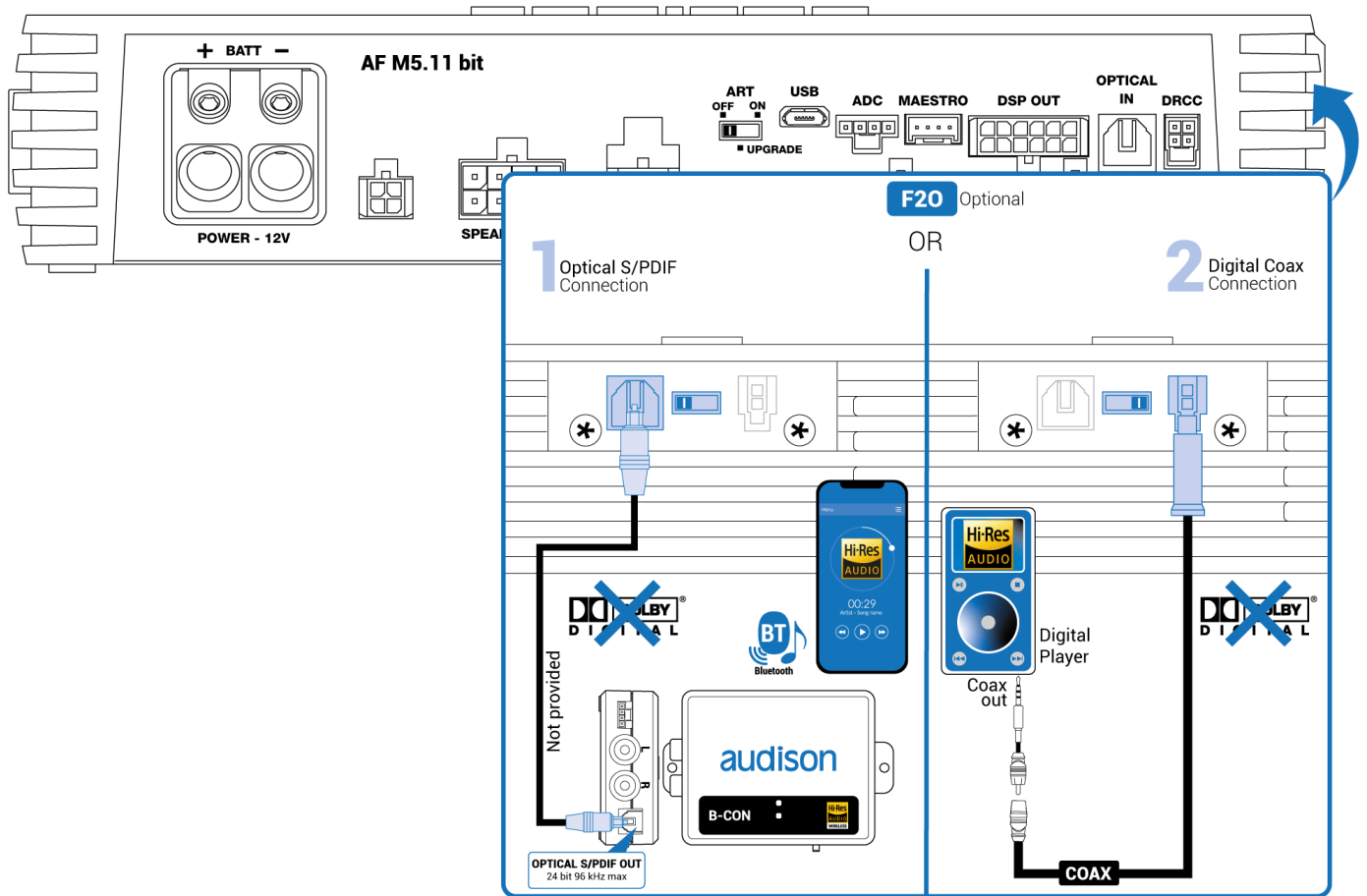

WARNING: the digital input accepts up to 192 kHz / 24 bit stereo PCM signals. So DOLBY DIGITAL (AC3) multi-channel signals coming from audio/video sources (such as the audio of a film in DVD or DTS can not be reproduced). The output of these devices will therefore have to be set in STEREO mode for the signal to be reproduced.

How to select the OPTICAL 2 input:

1. Using the DRC AC, selecting the OPTICAL input.
2. Using one of the "CONTROL" terminals properly set (*see sec. 7.3.2*). This command is active connecting the terminal to + 12V.
3. Using the PC Software.